



## Design and Operation of Mini-TEA CO<sub>2</sub> Laser and Investigation of Preionization Effect

Adawiya J. Haider and Falih H. Hamza

*School of Applied Sciences, University of Technology, Baghdad, IRAQ*  
e.mail: adawiya\_haider@yahoo.com

(Received 12 October 2003; accepted 8 August 2004)

**Abstract:** A Mini-TEA CO<sub>2</sub> laser system was designed and operated to obtain a pulse at 10.6 μm. Output energy of 30 mJ, with preionization pins, and pulse duration of 100ns were obtained. While an output energy of 6mJ and pulse duration of 100 ns in absence of pre-ionization were obtained. The system was operated with Ernest profile main-discharge electrodes. Dependencies of supply voltage and output laser energy on the pressure inside laser cavity were investigated as well as dependencies of supply voltage and output energy on the main capacitor(8CO<sub>2</sub> : 8N<sub>2</sub> : 82He :2CO). Efficiency of was calculated to be 4.4%.

### Introduction

All previous innovations have lead to advanced understanding of discharge-plasma mechanism at atmospheric pressure (TEA) or multiples to laser exciting and steady glow-discharge continuity. The main parameter controlling plasma behavior in the semi-steady-state system is the ratio of electric field ( $E$ ) to gas density ( $N$ ). This parameter ( $E/N$ ) differs in case of ultraviolet (UV) or electron-beam (EB) preionization systems.

There are two important applications of pulsed CO<sub>2</sub> lasers such as optical rangefinders [1] and tracking systems [2] those do not need to large output energy, but require small-size and (often linewidth tunability) high repetition rate. Sometimes, it is desired to circulate the gas, so such systems are provided with gas-circulation unit and the operation is so effective at atmosphere pressure or nearby, mostly. Systems are sometimes operated at double-atmospheric pressures. The main problem in these sealed-off systems is the dissociation of CO<sub>2</sub> molecules during the electrical discharge since loss of CO<sub>2</sub> is occurred after 2000-5000 output pulses. Dissociation of CO<sub>2</sub> molecules in the active medium result in O<sub>2</sub>, then it combines soon with

active-medium electrons through the time gap (delay) between main discharge and preionization. This leads to decrease electronic density of active medium (preionization and main discharge electrons) leading to instability of main discharge and arcing.

The effects of adding H<sub>2</sub> and CO to flow systems and using slicing spark-gaps as initial source to produce UV radiation were investigated [3]. It is found more suitable in operation than case of using trigger-wire as a preionizer, additional to possibility of increasing CO<sub>2</sub> concentration without affecting operation conditions and no arcing.

A simple Mini-CO<sub>2</sub> laser was developed to operate at atmospheric pressure or above with steady photonic ionization [4] and 250 mJ output energy was obtained. An output energy of 35 mJ was obtained from an active medium of 100x3x5 mm<sup>3</sup> in volume [5]. More than 60 mJ output energy with preionization-pins on the two sides of main electrodes was obtained from a Mini-TEA CO<sub>2</sub> laser [6].

Output energy of 180 mJ at pressure less than 3 bars, with same previous preionization technique, was obtained [7]. Life of mini-systems rises above 10<sup>6</sup> pulses with transverse excitation at atmospheric pressure using corona-

preionization technique and maximum output power of 350 kW was obtained [8]. Single frequency and 8 mJ output were obtained from a very-simple design using Bloom-Lein circuit [9].

The most important problem in face of researchers to construct TEA CO<sub>2</sub> lasers is high current density applied to the active medium leading to formation of unstable plasma which results in narrow electrical-spark streams called "bright arcs" [10].

In most applications of molecular-gas lasers (as CO<sub>2</sub> lasers), it is necessary that laser system should operate with self-sustained glow discharge including Vibrational excitation to lasing levels in CO<sub>2</sub>. There is a certain value for product of pressure and electrodes separate at which glow takes place and the voltage is breakdown voltage. It depends on gas type, electrode profile and material, and it is affected by existence or not of external magnetic field.

Converting to arcing region should be avoided always since it results in gas ionization in molecular-gas lasers that reduces active-medium volume and output power and hence destroys lasing action. Also, converting to arcing region may result plasma instability due to rising temperatures, especially at the cathode. So, the rise of temperature, as well as increase of current taken by laser system, should be avoided.

To reduce arcing in TEA CO<sub>2</sub> laser design, the following should be considered:

- 1- Pulsed and fast excitation and high  $E/N$  value.
- 2- Preionization to provide electrons before main discharge, so it can be operating at low  $E/N$  value.

The time required to steady discharge to occur should be shorter than time of converting glow to arc discharge. This time is about  $10^{-3}$  -  $10^{-4}$ s [11]. The  $E/N$  value differs as gas mixture differs since it depends on concentrations of gases inside the cavity. As mentioned previously, the optimum value of  $E/N$  is when the condition above is satisfied where  $E/N$  is lesser than its value at the beginning of discharge. In this case,  $E/N$  depends no on current density and electrode separating but on the gas mixture.

## Experiment

Mini-TEA CO<sub>2</sub> laser cavity consisted of two Perspex rectangular parts was designed and constructed, the first was 140 mm in length, 80 mm in width and 79 mm in depth and open from bottom side. The dimensions of base were 200x140x25 mm<sup>3</sup>, surrounded by a groove containing viton rectangular O-ring. The second part was a Perspex plate of same dimensions of the base. It was maintained using 10 stainless-steel screws. To connect main electrodes to supply cables, there were two parallel holes on the top and bottom faces with 11 mm in diameter. From center of top-face hole to 40 mm, there was another similar hole to maintain the first pin of preionization pins by a screw.

Two holes were made, one on each side of cavity, with 7 mm diameter and opposite-placed for gas inlet and outlet. On each side of cavity, there was a slice (of 105 mm in length, 28 mm in width and 3 mm thickness) for a copper part of same dimensions. Fig. (1) indicates the mechanical construction of Mini-TEA CO<sub>2</sub> laser system.

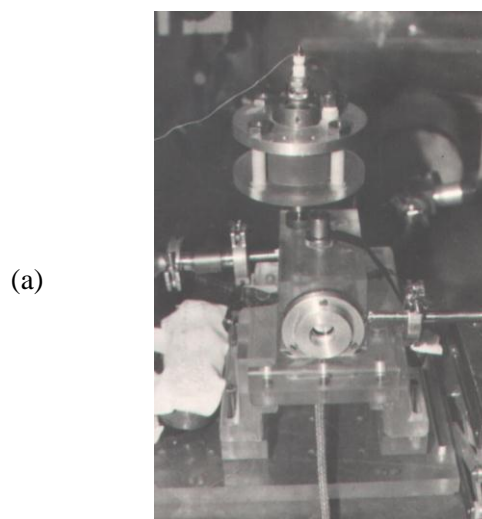

(a)

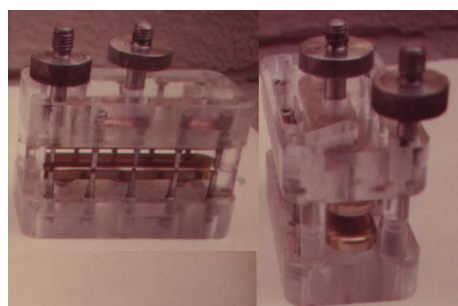

(b)

**Fig. (1):** Mechanical construction of Mini- TEA CO<sub>2</sub> laser system; (a) Laser head (b) Preionization pins and main electrodes holder

Preionization pins are 20 stainless-steel spark (pin) of 27 mm in length, 13 mm screw. 20 pins

were made as needle-head and another 20 pins were made as hemispherical in 2 mm diameter. The main electrodes were fixed at the top Perspex part to represent high-voltage terminal, while the bottom part represented common terminal. The separation between preionization pins was 2 mm.

A steady 32 kV-500 mA negative-voltage power supply, shown in Fig. (2), was used to charge the main three ceramic capacitors (each of 2.4 nF) those connected in parallel mode. A 4.7 kΩ resistance was connected to the main bank capacitor to limit discharge time (a 500 pF capacitor is connected to the main electrodes to keep discharge stability). The preionization capacitors were 20 pF ceramic type.

The mixture was 8:8:82:2 of CO<sub>2</sub>:N<sub>2</sub>:He:CO, were CO is the catalyst. The resonator was containing of two parallel mirrors, the back one was a gold-coated copper and perfect reflective,

the front one was a germanium and 0.6 reflective. Each mirror is 50 mm diameter and 5 mm thickness, and the separation was 140 mm.

Two types of detectors was used in this work, the first one was a thermal type operates at room temperature, minimum energy of 20 μJ and maximum energy of 1 J were detectable. The second one was HgCdTe IR-detector with 15 mV/W sensitivity and 1mm<sup>2</sup> sensitive area. Both detectors type Rofin 7410 and there were connected to storage oscilloscope (CRO) to read the output energy. A high-voltage probe till 40 kV, 1000 times damping, 5 ns response time was connected to CRO to measure pulse voltage at laser terminals.

The total current through plasma was measured using a differential Rogowski coil [12-14].

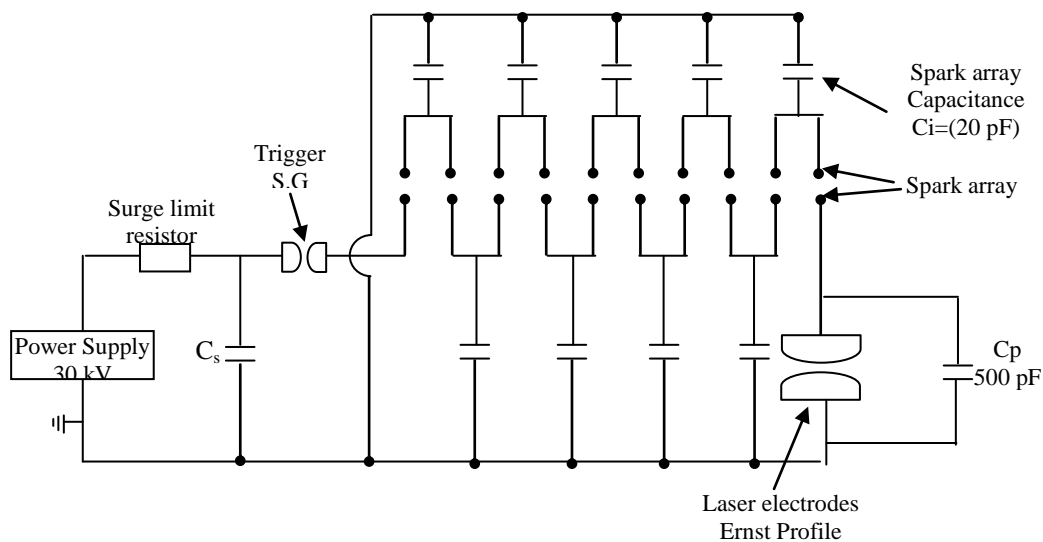

Fig. (2): Charge-transfer circuit used in this system.

### Results and Discussion

The laser gases were irradiated by UV radiation from sparks directly within the laser medium. This produces a relatively low level of ionization which is used to condition the medium prior to the application of the main discharge voltage. Therefore, the dependence of laser energy of put on supplied voltage and comparison of the output energy with preionization and without it has been

investigated in Fig.(3), which shows both increased linearly with increasing supplied voltage.

The maximum laser output energy was 30 mJ with preionization and the uniform preionization of this type self-sustained discharge allows for high excitation rate, i.e. high input energy, comparable to those of without preionization system.

○ With preionization    □ Without preionization

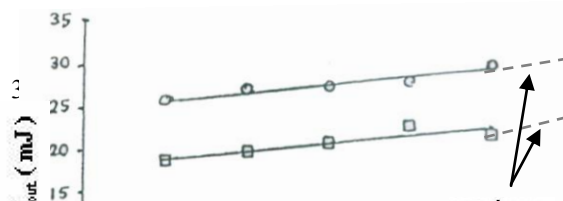

**Fig. (3):** Output laser energy vs supply voltage with and without preionizer.

Variation of laser energy output with total gas pressure is shown in Fig. (4), the relation is non-linear, since the laser output energy increases as gas pressure does, but it decreases with the continuous-increasing pressure.

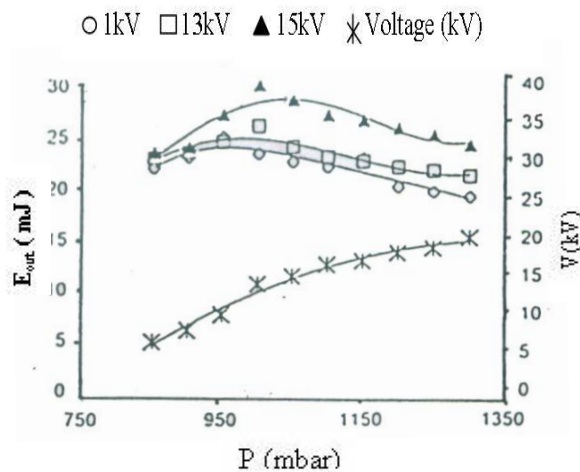

**Fig. (4):** Output laser energy and supply voltage vs gas pressure.

The maximum output energy was 30mJ at 1000 mbar gas pressure. Decrease in output energy can be explained as; increasing pressure leads to rise number of gas molecules inside lasing medium. Hence discharge energy absorbed by molecules will be lost as a thermal transfer due to collisions among gas molecules, i.e., they have no enough time to stay at excited-laser levels to achieve population inversion required for more lasing-energy. From Fig. (4), variation of voltage with gas pressure can be indicated where applied voltage increases linearly as pressure increases since the number of active medium molecules increases, hence applied voltage between main-discharge electrodes increases to be able to excite all

molecules and lasing action occurs. So, maximum output laser energy varies as applied voltage varies, i.e., for each value of applied voltage there is an optimum value of pressure [15].

Output laser energy increases as well as input energy until glow discharge converts to arcing region at certain value determined by gas total pressure. From Fig. (5), maximum efficiency can be calculated to be 4.4% at 30 mJ output and 15 kV supply voltage as [16]:

$$\eta = E_{out} / E_{in} = 2E_{out} / CV_o^2$$

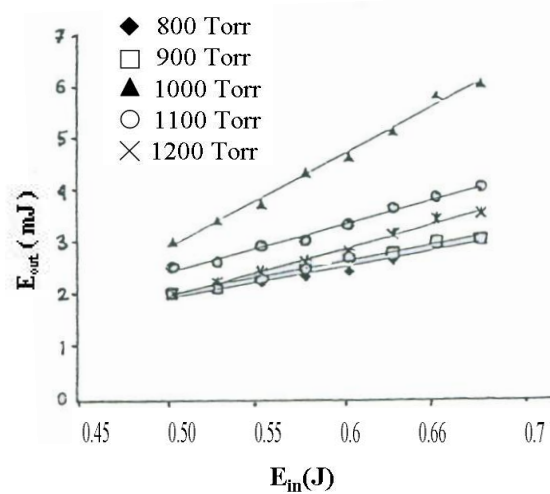

**Fig. (5):** Output laser energy vs. input energy for different pressures.

The dependence of laser energy output on supplied voltage for different values of main bank capacitor has been investigated, as shown in Fig.(6).

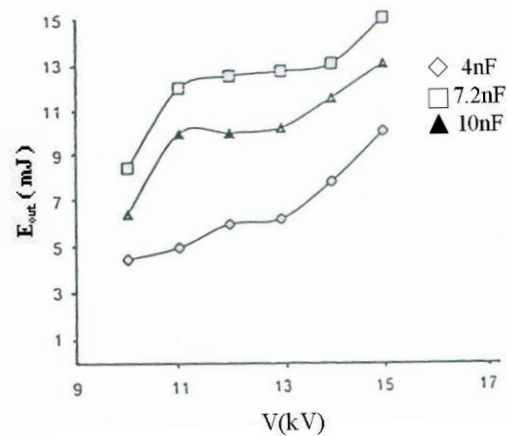
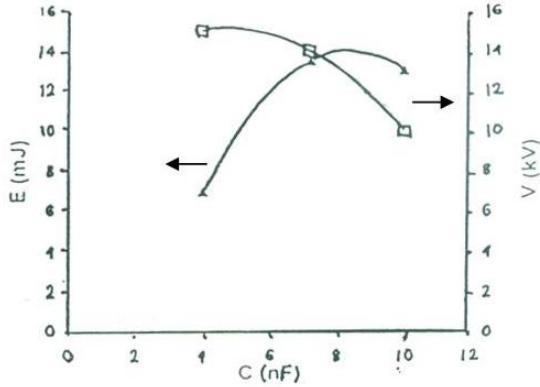

**Fig. (6):** Output laser energy vs. supply voltage for different bank capacitance.

It indicates the variation of output energy with supply voltage for different values of main



bank capacitor (4 nF at 12 kV, 6 nF at 11.5 kV and 10nF at 11 kV). In Fig. (7), the variation of both output energy and supply voltage with bank capacitance is shown.



**Fig. (7):** Output laser energy and supply voltage vs. bank capacitance.

Increasing capacitance leads to decrease optimum operating-voltage, hence decrease output energy. Increasing maximum energy transformed to plasma causes this; the optimum value of bank capacitor was 6nF at operating voltage 15 kV as in Fig. (7).

Figure (8) is a plot of the discharge current obtained as a function of pressure mixture. Shows the maximum discharge current available at the optimum voltage as a function of pressure.

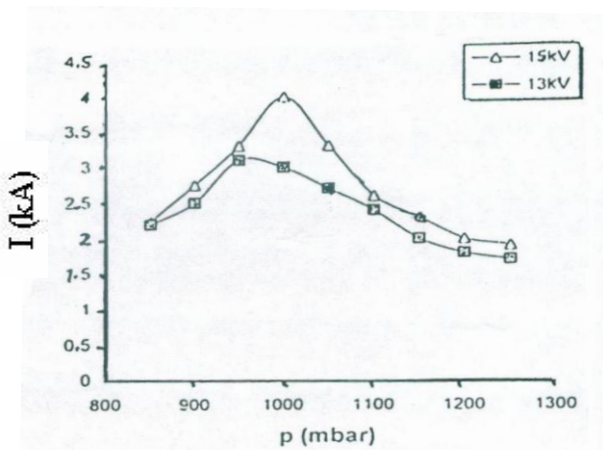

**Fig. (8):** Discharge current vs. gas pressure for different voltages.

The curve shows a clear peak which occurs at 1000 mbar corresponding variation in the best voltage and it decreases with increasing pressure, because the collisional deactivation was greater in the higher pressure region.

The E/P was measured as a function of pressures with variable voltage and the result shown by the plotted points in Fig.(9).

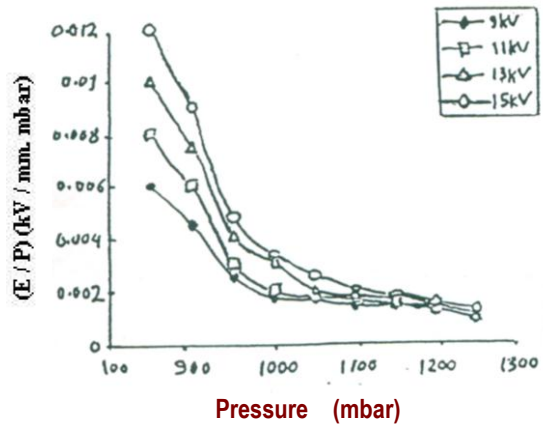

**Fig. (9):** Variation of E/P parameter vs. gas pressure for different voltages.

The discharge behavior depend of the parameter (E/P or E/N) was studies many years ago in a very different discharge arrangement by Pan et al. [10]. From it shows the E/P values falls as the pressure increases; thus in principle one should be able to tailor the E/P value of the discharge favor efficient energy transfer to the CO<sub>2</sub> upper laser level. The optimum laser performance in our system is achieved at (E/P = 0.004 kV/mbar).

Figure (10) is the output laser pulse where the sharp peak can be seen and the full-width half-maximum (FWHM) is 100 ns and the ripple of pulse-tail shown is due to increase of N<sub>2</sub> concentration in gas mixture.

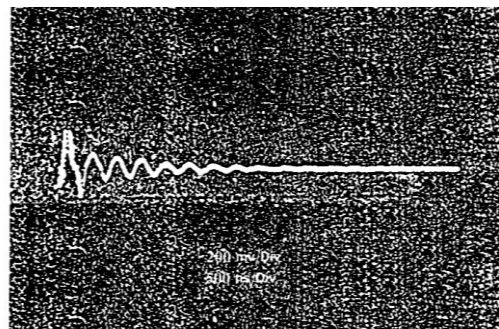

**Fig. (10):** Output laser pulse of Mini-TEA CO<sub>2</sub> laser system with N<sub>2</sub> rich gas mixture, 200 mV/div., 500 ns/div.

### Conclusion

In this design, Ernst profiles electrodes were taken as a model to be used, there is recent design that lead to better uniformity and more compactness of the electrodes profiles. The optimum value of operation running ( $K_o= 0.2$ ) has been chosen in electrodes design.

The photon preionization (pins) methods of plasma conditioning provides the advantages of high conversion efficiency and energy extraction in laser system the design gives rise of flexible operation condition following an output energy of 30 mJ at 14 kV at 1 Hz PRF.

Efficiency of system was calculated to be 4.4% at 30 mJ output and 0.675 J input energy, this is good result since previous results were ranging at 0.88 - 13 %. Increasing capacitance leads to decrease operating voltages, hence output energy.

### References

1- M.J. Taylor, P.H. Davies, D.V. Brown and W.F. Wood, *Appl. Opt.* **17**, 885 (1979).

- 2- D.S. Stark, P.H. Cross and H. Soster, *IEEE J. Quant. Electr.* **11**, 774 (1975).
- 3- H. Shields, A. Smith and B. Norris, *J. Phys. D: Appl. Phys.* **9**, 1587 (1976).
- 4- D.J. Brint, V. Hasson and T.I Salamon, *J. Phys.E: Sci. Inst.* **10**, 370 (1976).
- 5- G. Ernest, *Rev. Sci. Inst.* **48**, 1281 (1977).
- 6- N. Menyuk and P.F. Moutton, *Rev. Sci. Inst.* **51**, 216 (1980).
- 7- Chapman and Hall Ltd.: *Opt. and Quant. Electr.* **13**, 433 (1981).
- 8- R. Marchetti and E. Penco, *Appl. Phys. Lett.* **41**, 601 (1982).
- 9- H. Cao, H. Wang, Y. Chen, M. Che and X. Hu, *Infrared Phys.* **29**, 343 (1989).
- 10- Y. Pan, A. Bernhardt and J. Simpson, *J. Rev. Sci. Inst.* **43**, 662 (1972)
- 11- J. Verdeyen "Laser Electronics", Prentice-Hall Inc., 1981, p. 133.
- 12- K. Natly, R. Zowarka and L. Hall, *IEEE. Trans. on Mag.* **20**, 328 (1984).
- 13- Y. Takenaka, *IEEE. J. Quantum. Electr.* **27**, 2482 (1991).

## تصميم وتشغيل منظومة ليزر ثنائي أوكسيد الكربون صغيرة الحجم ودراسة تأثير التأين الأولي على أدائها

عدوية جمعة حيدر      فالح حسن حمزة

فرع الليزر، قسم العلوم التطبيقية، الجامعة التكنولوجية، ص.ب 35010 بغداد، العراق

في هذا البحث، جرى تصميم وتشغيل منظومة ليزر ثنائي أوكسيد الكربون صغيرة الحجم للحصول على نبضة عند الطول الموجي  $10.6 \mu\text{m}$ . تم الحصول على طاقة خرج ليزري 30 mJ وأمد نبضة 100 ns باستخدام أوتاد التأين الأولي، فيما كانت طاقة الخرج 6 mJ لنفس أمد النبضة عند عدم استخدام أوتاد التأين الأولي. جرى تشغيل المنظومة باستخدام أقطاب تفريغ رئيسي نوع (Ernst-profile). كما تمت دراسة اعتماد الفولتية المجهزة وطاقة الخرج الليزري على الضغط داخل حجرة الليزر وكذلك اعتمادهما على قيمة متسعة الخزن الرئيسية  $(8\text{CO}_2 : 8\text{N}_2 : 82\text{He} : 2\text{CO})$ . حسب كفاءة المنظومة وكانت بحدود 4.4%.

### الخلاصة